

Mobius® Chrom 20 System

For Purification of Clinical and Process Scale Biologics

The Mobius® Chrom 20 system is a flexible, automated, single-use chromatography system that enables consistent and reliable separation and purification of mAbs, vaccines, plasma, and therapeutic proteins at clinical and process scales.

The innovative single-use flowpath reduces contamination risk and gives you the confidence to tackle any chromatography challenge, while the flexible design featuring a standard hardware platform that can be combined with a selection of options, empowers you to meet your unique process requirements.

The Mobius® Chrom 20 system delivers optimal operational flexibility for processes up to 2000L with flow rates up to 20L/min, a 5:1 turn down ratio at process scale, and enhanced isocratic and linear gradient accuracy.



Benefits

Easy to Use

Our unique clamshell and single-use Flexware® clamshell assemblies were designed to offer ultimate ease of use from preparation to production. Simply insert the assembly into the clamshell and connect the tubings.

Safe & Reliable Process

Our 100% single-use, gamma-irradiated Flexware® assemblies provide quick product changeover with reduced contamination risk and cleaning for greater efficiency and process security.

The high gradient accuracy of the system enhances separation performance making it ideal for challenging processes.

Flexible

Easily scale-down to lower column sizes while maintaining high accuracy to meet broader processing requirements. Ability to cover multiple scales and applications offers maximum return on investment.

User-friendly

The system was designed with operator comfort and safety in mind and features a movable screen for operator convenience. The stainless-steel surface is easy to clean and the accessible components facilitate maintenance.

System Components

The Mobius® Chrom 20 system is made up of a base system and configurable options that can be added to design a system that best meets your purification process and challenges.

The base cart is the heart of the system and houses the clamshell and automation software.

The unique clamshell design ensures simple installation of the flowpaths so your process is up and running rapidly, while the optional clamshell lift enables a single technician to assemble and maintain the system.

The system also shares common elements with our other unit operations, such as an intuitive software interface, assembly material (PureFlex™ film), and maintenance components, making training and validation easier across scales and applications.

Mobius® Chrom 20 System Configurations

The basic configuration includes:

- Clamshell
- Pump cart
- Base cart
- Post-column instrumentation

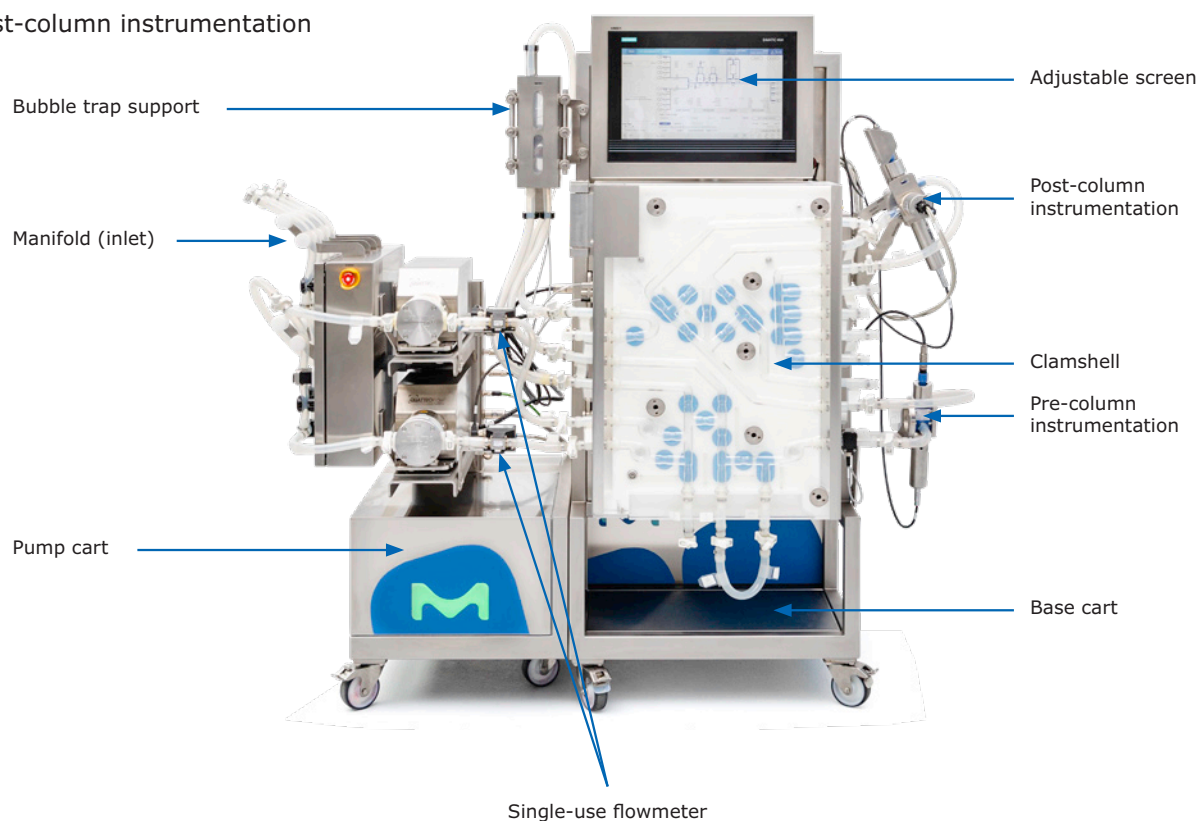

The system options and accessories include:



Pre-column 0,2µm filter and its support for protecting the column



Pre-column instrumentation for conductivity and pH measurement



Keyboard support for enhanced ease of use



Clamshell lift for one-man assembly and maintenance

Mobius® Chrom 20 Flexware® Assemblies

Single-use Flexware® assemblies deliver equivalent performance to that of traditional stainless-steel systems, while providing maximized contamination control. Assemblies minimize dead space, decreasing the risk of contamination to virtually zero, while ensuring high gradient accuracy. The assemblies are delivered gamma-irradiated, ready-to-use, and are clearly labeled, significantly reducing the risk of installation error and the challenges typically associated with installing single-use flow paths.

Benefits of our 100% Single-use Flowpaths

- Fast changeover and reduced contamination risk from previous batches in multi-product and multi-scale productions
- Combination of clamshell and Flexware® clamshell assembly offers easy installation compared to classic tubing
- Reduced hold-up volume contributes to the enhanced accuracy of the system
- Reduced number of connections versus traditional single-use assemblies decreases the risk of integrity failure
- The clamshell assemblies are 100% integrity tested during manufacturing, ensuring reliable performance



Flexware® clamshell assembly labels



Mobius® Chrom 20 system clamshell and Flexware® clamshell assembly

Common Control Platform® (CCP®) Software

Our CCP® 6.8 software on Windows® 10 provides a single software platform across our portfolio of automated systems for a familiar look and feel at each step of your process and reduced training time for operators.

The software offers recipe driven processing that eliminates manual operation, reduces process variability, and minimizes risk of errors. Process operations are easily created and managed using the recipe editor, each aspect of your process is monitored from the HMI (Human Machine Interface), and the report client provides state-of-the-art batch reports.

The software is designed for cGMP facilities, is in line with GAMP® 5 recommendations for automation software, and fulfills FDA guideline 21 CFR Part 11 requirements for electronic records and signatures.

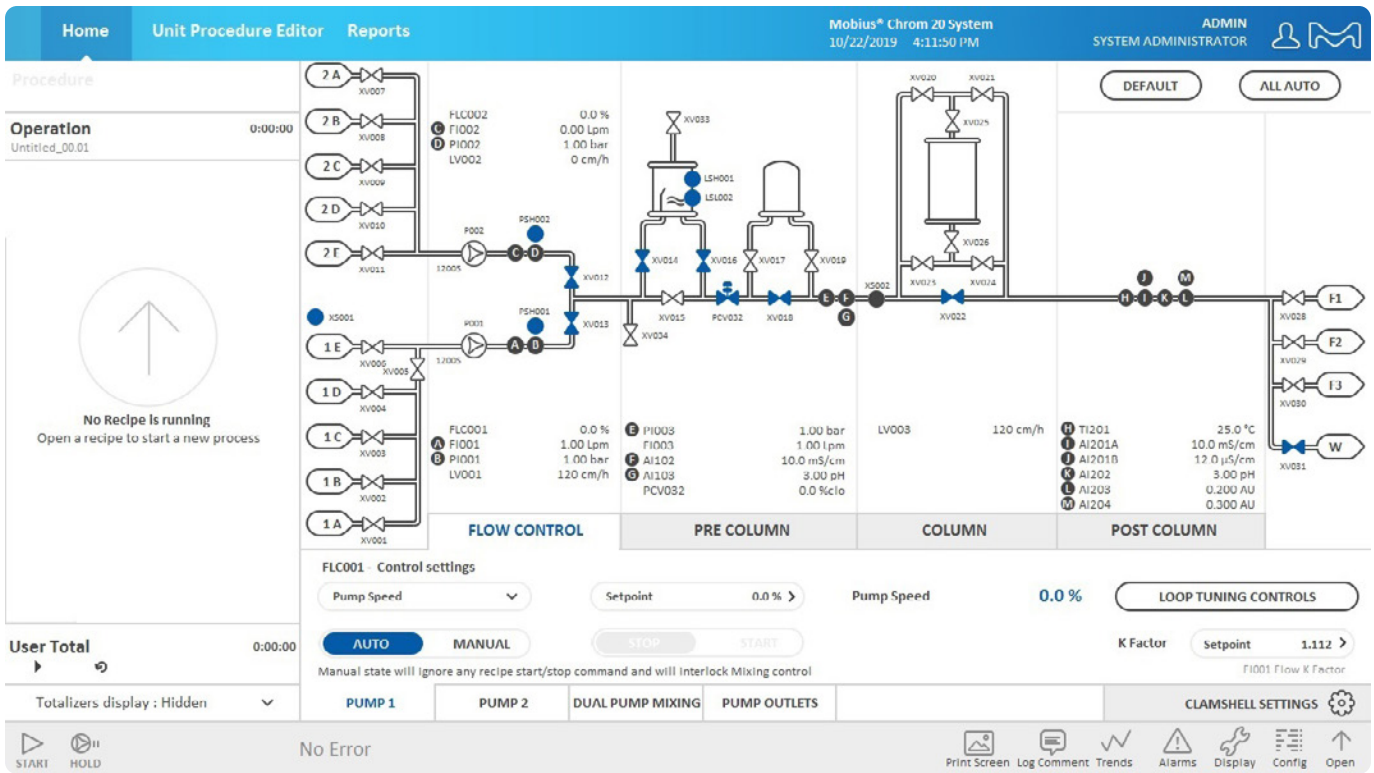

Mobius® Chrom 20 system CCP® software interface

Optimized, Robust Chromatography Performance

Exceptional gradient accuracy performance

The system is designed to deliver high accuracy gradients using pump-based mixing over an extended flowrate range. The test results below illustrate the better than 2% accuracy obtained from 4 to 20 L/min over a mixing range of 10-90% in step and linear gradient modes. This unique performance enables enhanced separation in a fully single-use mode to meet any chromatography challenge.

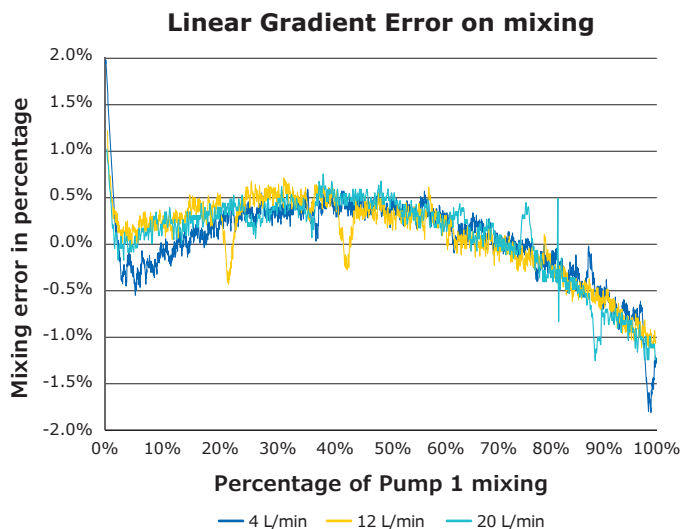

Figure 1: Linear Gradient (%) at 4 L/min, 12 L/min and 20 L/min

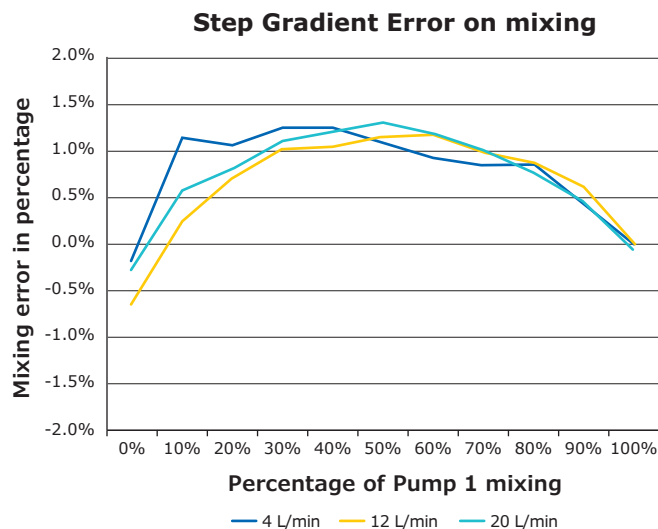

Figure 2: Step Gradient (%) at 4 L/min, 12 L/min and 20 L/min

Low pressure drop over full flow rate range

The system is designed to minimize pressure drop across the full flow rate range. The system pressure drop is below 1 bar at max flowrate.

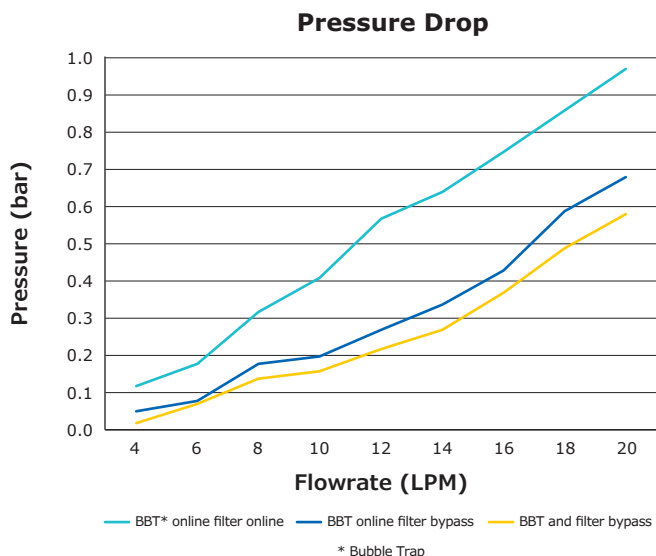

Figure 3: Pressure drop (bar) at 4 L/min, 12 L/min and 20 L/min

Related products to support your chromatography process

QuikScale® Chromatography Columns

Designed to achieve maximized throughput, our QuikScale® columns are easily packed to deliver optimal resolution across a wide range of chromatographic applications, accommodating all media types. The flow distributor assures full, uniform media utilization within the column, assuring reproducible and reliable separations. QuikScale® chromatography columns offer fast packing and unpacking, predictable and scalable performances, and flow adjuster seal technology for fail-safe operation in a choice of column tube materials for any application.



IsoPak™ Chromatography Process Columns

Recognized for their proven chromatographic performance, IsoPak™ columns provide faster, cleaner, and more consistent packing and unpacking for reproducible results. IsoPak™ columns are available in a variety of options including IsoPak™ valves, antijet, hydraulic assist, and proven flow cell distribution to provide consistent performance and scalability across a wide range of column diameters.



Industry-Leading Affinity and Ion Exchange Chromatography Medias

Eshmuno® Resin

This unique family of ion-exchange and affinity resins is specifically designed for highly productive downstream purification.

Fractogel® Resin

This tentacle-modified synthetic polymer resin is designed for ion exchange, hydrophobic interaction, size exclusion and metal chelate affinity.

ProSep® Ultra Plus Resin

Designed for cost-effective, large-scale purification of higher titer therapeutic antibodies, the ProSep® Ultra Plus Resin is a high binding capacity Protein A affinity chromatography media.



Supply Robustness and Control. Stay Ahead.

Mega-trends are contributing to a boom in the biopharmaceutical industry. As a leading partner and supplier to the industry, we continue to strengthen our supply chain to support our commitment of on-time delivery reliability and product quality to help you stay ahead.

To learn more about our program, please visit our website at EMDMillipore.com/StayAhead.

Mobius® Chrom 20 System Services

The pharmaceutical and biotechnology industries are highly regulated and, to help you navigate this challenging environment, we offer a wide range of services. These services help you save time, lower costs, and comply with regulations. For your peace of mind, all our services are performed by our global experts who have an intimate knowledge of our equipment backed by decades of experience.

Qualification Services

Our qualification services are designed to make the integration of our system into your process as seamless as possible and ensure your equipment is properly installed and functioning per your pre-defined requirements.

- Factory acceptance test (FAT)
- Site acceptance test (SAT) (*combined with IQ/OQ*)
- Installation qualification/operational qualification (IQ/OQ) (*combined with SAT*)
- Performance qualification support (PQ)

Training Services

Appropriate training for users is not only a cGMP requirement, it also ensures your staff has the expertise to operate and manage the system as part of your manufacturing process.

Our training offering has been designed to make your staff more autonomous in managing your system and your process while saving time and money. Our training services cover system use and programming with interactive hands-on sessions and, depending on the training you select, may also include:

- Installing the Flexware® assemblies
- Interacting with the Human Machine Interface
- Manual and automatic system operation
- Troubleshooting issues
- Creating and managing your own recipes
- Process recommendations

These trainings can be delivered either at your site or in our M Lab™ Collaboration Centers. Please contact your local representative or email ilearn@milliporesigma.com to discuss our training offering.

Maintenance & Repair Services

Regular maintenance of your system is critical to avoid unnecessary downtime for repairs, minimize the risk of process deviations, and maintain optimum performance and compliance.

- Preventive maintenance (PM)
- Corrective Maintenance (CM)
- Spare parts – Check the Mobius® Chrom 20 spare parts list for ordering information and details (MS_CA5325EN.)

Specialized Services

CCP® Software Recipe Design

Every process is unique and, to ensure that your system is optimized to deliver the best performance, our biomanufacturing engineers will configure your process into your own CCP® software recipe. This allows your system to run fully automatic, resulting in consistency and reduced operator error.

For catalogue numbers, please refer to the ordering information at the end of the document.

Mobius® Chrom 20 System and Flexware® Assemblies Specifications

General System Specifications

Specification	Mobius® Chrom 20 System	
Flow Range	In gradient mode within accuracy specifications: 240-1200L/h In Isocratic mode: 24-1200L/h	
Pumps	Model	Quattroflow 1200S x 2
	Maximum Pressure	4 bar
Valves	On/Off Valves	Inside Clamshell: Automatic pneumatic piston Inlet Manifold: Automatic pinch valve for 5/8" ID tubing
	Valve control (after Bubble Trap)	Pneumatic piston with pressure regulator

Mechanical Specifications: System and Assemblies

Specification	Mobius® Chrom 20 System	
System Dimensions	Pump & Base carts connected H x W x D in mm	1727 x 1715 x 800 ± 20 mm (68 x 67.5 x 31.5 in.)
Net Weight	Base cart with Clamshell	365 kg (805 lbs)
	Pump cart with 2 Pumps and Manifold	160 kg (353 lbs)
Materials of Construction	Wetted Components USP<88> Class VI compliant material	
	Tubing	Silicone
	Flexware® Clamshell Assembly	Pureflex™ Film, polyethylene fittings and silicone gaskets, polypropylene
	Pump Head	EPDM, Santoprene® and polypropylene
	Connectors	Polypropylene, polysulfone
	Flowmeter	Polysulfone and Hastelloy C22 electrodes
	UV, Conductivity and pH Sensor (MU)	Quartz, EPDM and stainless steel 316L
	UV, Conductivity and pH Sensor (SUC)	Polysulfone Quartz, EPDM and stainless steel 316L (pins only)
	Non-Wetted Components	
	Carts frame & panels	Stainless steel 304L
Clamshell (rear)	POM	
Clamshell (front)	PMMA	
Valve Pads	Silicone	
Casters	8 (4 free, 4 locking) Inner : Polyamide 6 Rolling area : Polyurethane	
Connections	Inlets (10)	¾" TC
	Outlets, 3 Fractions + 1 waste	¾" TC
	Filters	¾" TC
	Column	¾" TC
	Pneumatic	¾" TC

Operating Specifications

Specification	Mobius® Chrom 20 System	
Total Operating Time	Flexware® Assemblies	Validated for 24 hours operation 50 cycles (50 valve openings and 50 valve closings) per valve The integrity of the installation may be compromised if used for more than 50 cycles
	Valve Pads	Do not exceed 1200 cycles or 6 months of operation
Product Temperature Range	20 to 30°C (68 to 86°F)	
Maximum Pressure	Pump 1 Manifold	0 to 2 bar (0 to 29 psi)
	Pump 2 Manifold	0 to 2 bar (0 to 29 psi)
	Pump Assembly	0 to 4 bar (0 to 58 psi)
	Bubble Trap Assembly	0 to 4 bar (0 to 58 psi)
	Clamshell assembly	0 to 4 bar (0 to 58 psi)
	Precolumn Filter Assembly	0 to 4 bar (0 to 58 psi)
	Pre-column Instrumentation Assembly	0 to 4 bar (0 to 58 psi)
	Post-column Instrumentation Assembly	0 to 2 bar (0 to 29 psi)
	Column Assembly	0 to 4 bar (0 to 58 psi)
System Operating Temperature	20 to 30°C (68 to 86°F)	
Operating Humidity	10 to 90% (non condensing)	

Power and Air Supply Specifications

Specification	Mobius® Chrom 20 System
Power Supply	220-240VAC, 50/60 Hz, 1 phase, 6.5 A max or 100-120VAC, 50/60 Hz, 1 phase, 13.6 A max
	Maximum consumption 1.6 KW
Pneumatic Air Supply	6 bar (87 psi) min, 10 bar (145 psi) maximum, oil free
	Maximum consumption 4 L/min

Instrument Specifications and Performances

Specification	Tag*	Range/Setting/Type/Accuracy	Process Connection
Pressure Indicators	PIT001 PIT002 PT003	0-4 bar (0-58 psi) ± 0.2 bar (2.9 psi)	Non-intrusive
High Pressure Switches	PSH001 PSH002	4.2 bar (60 psi)	Non-intrusive
Single-Use Magnetic Flowmeters	FT001 FT002	± 2% MV between 0,4 L/min and 20 L/min	In-line
Temperature Sensors	TE201	2-30°C (35.6°F to 86°F) ± 1°C (33.8°F)	Combined with conductivity sensor
Single-use Conductivity Sensors	AE102 AE201A AE201B	Process: 0-100 mS/cm ±2% FS Cleaning: 0-50 µS/cm ±2% FS	In-line
pH Sensors	AE103 AE202	1-14 pH ±0.1 pH	In-line
Air Sensors	XS001 XS002	N/A	Non-intrusive
UV Sensors	AE203/204	AF45 : 0-3 AU ±2% FS OPL: 1 or 2.5 mm Wavelength: 280 nm AF46 : 0-2 AU ±2% FS OPL: 1 or 2.5 mm Wavelength: Dual 254/280 nm or 280/300 nm	In-line

Do not use UV Sensors in a condensing atmosphere. Condensation may lead to erroneous sensor readings.

*Refers to the labels on the system hardware

Ordering Information

Hardware

Catalogue Number	Description	Base Cart	Bubble Trap Support	Pump Cart with 2 Pumps and 2 Single-use Flowmeters	Single-use Pre-column Instrumentation Holder	280 nm	280/300 nm	254/280 nm	
		Standard				Option			
						SU Post-column Instrumentation			
China									
MCPXM20CNSB01	Mobius® Chrom 20 Post SU 280 nm	Included				•			
MCPXM20CNSB02	Mobius® Chrom 20 Post SU 280-300nm						•		
MCPXM20CNSB03	Mobius® Chrom 20 Post SU 254-280nm							•	
MCPXM20CNSBS1	Mobius® Chrom 20 Pre SU Post SU 280 nm		•	•					
MCPXM20CNSBS2	Mobius® Chrom 20 Pre SU Post SU 280-300nm		•		•				
MCPXM20CNSBS3	Mobius® Chrom 20 Pre SU Post SU 254-280nm		•					•	
European Union									
MCPXM20EUSB01	Mobius® Chrom 20 Post SU 280 nm	Included				•			
MCPXM20EUSB02	Mobius® Chrom 20 Post SU 280-300nm						•		
MCPXM20EUSB03	Mobius® Chrom 20 Post SU 254-280nm							•	
MCPXM20EUSBS1	Mobius® Chrom 20 Pre SU Post SU 280 nm		•	•					
MCPXM20EUSBS2	Mobius® Chrom 20 Pre SU Post SU 280-300nm		•		•				
MCPXM20EUSBS3	Mobius® Chrom 20 Pre SU Post SU 254-280nm		•					•	
Switzerland									
MCPXM20CHSB01	Mobius® Chrom 20 Post SU 280 nm	Included				•			
MCPXM20CHSB02	Mobius® Chrom 20 Post SU 280-300nm						•		
MCPXM20CHSB03	Mobius® Chrom 20 Post SU 254-280nm							•	
MCPXM20CHSBS1	Mobius® Chrom 20 Pre SU Post SU 280 nm		•	•					
MCPXM20CHSBS2	Mobius® Chrom 20 Pre SU Post SU 280-300nm		•		•				
MCPXM20CHSBS3	Mobius® Chrom 20 Pre SU Post SU 254-280nm		•					•	
United Kingdom									
MCPXM20UKSB01	Mobius® Chrom 20 Post SU 280 nm	Included				•			
MCPXM20UKSB02	Mobius® Chrom 20 Post SU 280-300nm						•		
MCPXM20UKSB03	Mobius® Chrom 20 Post SU 254-280nm							•	
MCPXM20UKSBS1	Mobius® Chrom 20 Pre SU Post SU 280 nm		•	•					
MCPXM20UKSBS2	Mobius® Chrom 20 Pre SU Post SU 280-300nm		•		•				
MCPXM20UKSBS3	Mobius® Chrom 20 Pre SU Post SU 254-280nm		•					•	

Hardware

Catalogue Number	Description	Base Cart	Bubble Trap Support	Pump Cart with 2 Pumps and 2 Single-use Flowmeters	Single-use Pre-column Instrumentation Holder	Option			
						Standard	SU Post-column Instrumentation		
							280 nm	280/300 nm	254/280 nm
Japan									
MCPXM20JPSB01	Mobius® Chrom 20 Post SU 280 nm	Included				•			
MCPXM20JPSB02	Mobius® Chrom 20 Post SU 280-300nm						•		
MCPXM20JPSB03	Mobius® Chrom 20 Post SU 254-280nm							•	
MCPXM20JPSBS1	Mobius® Chrom 20 Pre SU Post SU 280 nm		•	•					
MCPXM20JPSBS2	Mobius® Chrom 20 Pre SU Post SU 280-300nm		•		•				
MCPXM20JPSBS3	Mobius® Chrom 20 Pre SU Post SU 254-280nm		•					•	
Korea									
MCPXM20KRSB01	Mobius® Chrom 20 Post SU 280 nm	Included				•			
MCPXM20KRSB02	Mobius® Chrom 20 Post SU 280-300nm						•		
MCPXM20KRSB03	Mobius® Chrom 20 Post SU 254-280nm							•	
MCPXM20KRSBS1	Mobius® Chrom 20 Pre SU Post SU 280 nm		•	•					
MCPXM20KRSBS2	Mobius® Chrom 20 Pre SU Post SU 280-300nm		•		•				
MCPXM20KRSBS3	Mobius® Chrom 20 Pre SU Post SU 254-280nm		•					•	
North America									
MCPXM20NASB01	Mobius® Chrom 20 Post SU 280 nm	Included				•			
MCPXM20NASB02	Mobius® Chrom 20 Post SU 280-300nm						•		
MCPXM20NASB03	Mobius® Chrom 20 Post SU 254-280nm							•	
MCPXM20NASBS1	Mobius® Chrom 20 Pre SU Post SU 280 nm		•	•					
MCPXM20NASBS2	Mobius® Chrom 20 Pre SU Post SU 280-300nm		•		•				
MCPXM20NASBS3	Mobius® Chrom 20 Pre SU Post SU 254-280nm		•					•	
Accessories									
MBCLAMLIFT110V	Clamshell lift 110V (Specific to Mobius® Chrom 20 system)								
MBCLAMLIFT230V	Clamshell lift 230V (Specific to Mobius® Chrom 20 system)								
MBSPFMX20	Pre-column filter support for Mobius® Chrom 20 system								
MBSPKB	Keyboard support								
MBCLAMCABLE	Maintenance cable								
MBYOKECL	Yoke arm to convert an existing clamshell lift to Mobius® Chrom 20 system new clamshell design								

Flexware® kit

Catalogue Number	Description	Manifold line Pump 1	Manifold line Pump 2	Pump heads	Flowmeter assembly line 1	Flowmeter assembly line 2	Clamshell assembly	Bubble trap assembly	Filter assembly	Filter bypass assembly	Pre-column instrumentation	Pre-column bypass assembly	Column connection assembly	Post-column instrumentation	Post-column instrumentation
FXWXM20K0001	Mobius® Chrom 20 Flexware® kit (Post 1mm OPL)	1	1	2	1	1	1	1	0	1	0	1	1	1	0
FXWXM20K0002	Mobius® Chrom 20 Flexware® kit (Post 2,5mm OPL)	1	1	2	1	1	1	1	0	1	0	1	1	0	1
FXWXM20K0003	Mobius® Chrom 20 Flexware® kit (Filter + Post 1mm OPL)	1	1	2	1	1	1	1	1	0	0	1	1	1	0
FXWXM20K0004	Mobius® Chrom 20 Flexware® kit (Filter + Post 2,5mm OPL)	1	1	2	1	1	1	1	1	0	0	1	1	0	1
FXWXM20K0005	Mobius® Chrom 20 Flexware® kit (Pre + Post 1mm OPL)	1	1	2	1	1	1	1	0	1	1	0	1	1	0
FXWXM20K0006	Mobius® Chrom 20 Flexware® kit (Pre + Post 2,5mm OPL)	1	1	2	1	1	1	1	0	1	1	0	1	0	1
FXWXM20K0007	Mobius® Chrom 20 Flexware® kit (Filter + Pre + Post 1mm OPL)	1	1	2	1	1	1	1	1	0	1	0	1	1	0
FXWXM20K0008	Mobius® Chrom 20 Flexware® kit (Filter + Pre + Post 2,5mm OPL)	1	1	2	1	1	1	1	1	0	1	0	1	0	1
PMFXWKITXM20	Mobius® Chrom 20 Preventive Maintenance kit	0	0	1	1	0	1	0	0	2	1	1	0	1	0
FXWXM20BUBBL	Spare BBT and Flexware® Clamshell Assemblies	0	0	0	0	0	1	1	0	0	0	0	0	0	0

Services

Qualification

Please contact your local MilliporeSigma representative Mobius® Chrom 20 Factory Acceptance Test

SSVQUAGRA1 Mobius® Chrom 20 SAT & IQ/OQ execution protocol and travel

SSVQUAM202 Mobius® Chrom 20 full test package execution incl. protocol and travel

SSVQUAM201 Site acceptance test + Installation and operational qualification

Specialized Support

SSVRPCCPB CCP® recipe design, Qty 3

Maintenance & Repair

SSVPRMM20 Preventive maintenance execution incl. protocol & travel*

Please contact your local MilliporeSigma representative Repair

Spare parts

Please refer to spare part list available at EMDMillipore.com/Chrom20

*PMFXWKITXM20 kit should be ordered separately prior to preventive maintenance

To place an order or receive technical assistance

In the U.S. and Canada, call toll-free
1-800-645-5476

For other countries across Europe
and the world, please visit:
[EMDMillipore.com/offices](https://www.emdmillipore.com/offices)

For Technical Service, please visit:
[EMDMillipore.com/techservice](https://www.emdmillipore.com/techservice)

[EMDMillipore.com/Chrom20](https://www.emdmillipore.com/Chrom20)

MilliporeSigma
400 Summit Drive
Burlington, MA 01803

To place an order or receive technical assistance,
please visit [EMDMillipore.com/contactPS](https://www.emdmillipore.com/contactPS)

For additional information, please visit
[EMDMillipore.com/Chrom20](https://www.emdmillipore.com/Chrom20)

